

## EJERCICIO DE APLICACIÓN METODO DE LAS DEFORMACIONES

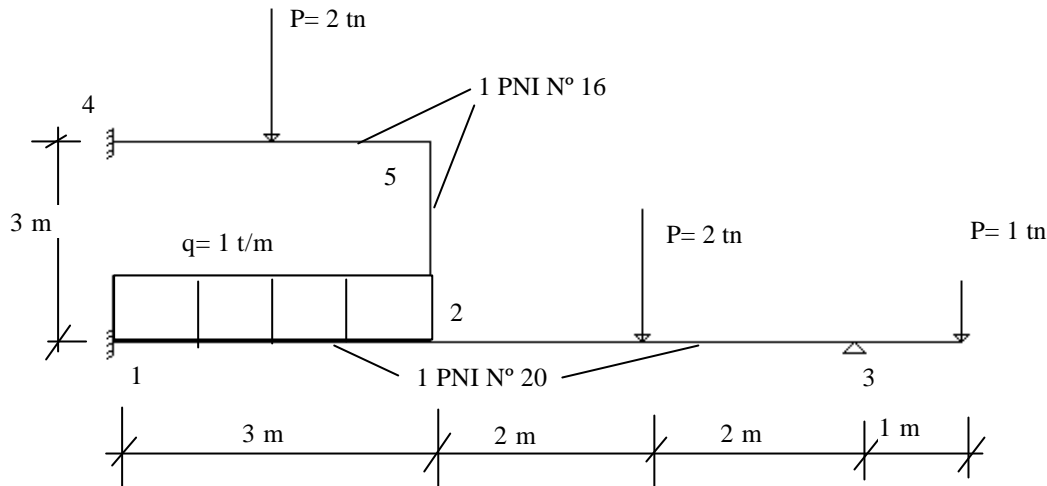

Características de los perfiles

PNI N° 16

$$I_x = 935 \text{ cm}^4$$

$$W_x = 117 \text{ cm}^3$$

$$F = 22.8 \text{ cm}^2$$

PNI N° 20

$$I_x = 2140 \text{ cm}^4$$

$$W_x = 214 \text{ cm}^3$$

$$F = 33.4 \text{ cm}^2$$

$$I_{12} = I_{23} = 2140 \text{ cm}^4$$

$$I_{25} = I_{45} = 935 \text{ cm}^4 = I_o$$

La ecuación de recurrencia vista en teoría era:

$$M_{ij} = M^o_{ij} + \frac{2.E.I_{i,j}}{L_{i,j}} [2.\omega_i + \omega_j - 3.\psi_{ij}]$$

multiplicando y dividiendo por  $I_o$  el segundo miembro de la ecuación anterior obtenemos:

$$M_{ij} = M^o_{ij} + \frac{2.E.I_{ij}}{L_{ij}} \cdot \frac{I_o}{I_o} [2.\omega_i + \omega_j - 3.\psi_{ij}] = M^o_{ij} + \frac{2.\alpha_{ij}}{L_{ij}} \left[ 2.\bar{\omega}_i + \bar{\omega}_j - 3.\bar{\psi}_{ij} \right]$$

siendo:

$$\alpha_{ij} = I_{ij} / I_o$$

$$\bar{\omega}_i = \omega_i \cdot E \cdot I_o$$

$$\bar{\omega}_j = \omega_j \cdot E \cdot I_o$$

$$\bar{\psi}_{ij} = \psi_{ji} \cdot E \cdot I_o$$

Datos:

por condición de vínculo

$$\omega_1 = \omega_4 = \psi_{25} = 0$$

Incógnitas:

$$\omega_2; \omega_3; \omega_5; \psi_{45}; \psi_{23}; \psi_{12}$$

Cómo el método no considera deformaciones por esfuerzo normal, entonces el desplazamiento vertical de los nudos 2 y 5 será el mismo.



Luego:

$$\Delta = L_{45} \cdot \psi_{45} = L_{12} \cdot \psi_{12} \rightarrow \psi_{12} = L_{45} / L_{12} \cdot \psi_{45}$$

Además, cómo el sentido de giro de la barra 1-2 es de distinto signo que el de la barra 2-3 será:

$$\Delta = -L_{23} \cdot \psi_{23} = L_{12} \cdot \psi_{12} \rightarrow \psi_{12} = -L_{23} / L_{12} \cdot \psi_{23}$$

Cálculo de los  $M^0_{i,j}$

$$M^0_{12} = -M^0_{21} = q \cdot l^2 / 12 = 0.75 \text{ tm}$$

$$M^0_{23} = -M^0_{32} = P \cdot l / 8 = 1.00 \text{ tm}$$

$$M^0_{45} = -M^0_{54} = P \cdot l / 8 = 0.75 \text{ tm}$$

Planteamos las ecuaciones de recurrencia para cada barra

$$\alpha_{12} = \alpha_{23} = 2.29 \quad \alpha_{45} = 1.00 = \alpha_{25} = 1.00$$

Barra 1-2

$$M_{12} = M^0_{12} + \frac{2 \cdot \alpha_{12}}{L_{12}} \left[ 2 \cdot \bar{\omega}_1 + \bar{\omega}_2 - 3 \cdot \bar{\psi}_{12} \right] = 0.75 + 2 \times 2.29 / 3 \left[ 2 \times 0 + \bar{\omega}_2 - 3 \times \bar{\psi}_{12} \right]$$

$$M_{12} = 0.75 + 1.5267 \bar{\omega}_2 + 6.107 \bar{\psi}_{23}$$

$$M_{21} = -0.75 + 3.053 \bar{\omega}_2 + 6.107 \bar{\psi}_{23}$$

Barra 2-3

$$M_{23} = 1.00 + 2.297 \bar{\omega}_2 + 1.145 \bar{\omega}_3 - 3.435 \bar{\psi}_{23}$$

$$M_{32} = -1.00 + 1.145 \bar{\omega}_2 + 2.29 \bar{\omega}_3 - 3.435 \bar{\psi}_{23}$$

Barra 4-5

$$M_{45} = 0.75 + 0.667 \bar{\omega}_5 + 2.667 \bar{\psi}_{23}$$

$$M_{54} = -0.75 + 1.333 \bar{\omega}_5 + 2.667 \bar{\psi}_{23}$$

Barra 2-5

$$M_{25} = 1.333 \bar{\omega}_2 + 0.667 \bar{\omega}_5$$

$$M_{52} = 0.667 \bar{\omega}_2 + 1.333 \bar{\omega}_5$$

Planteo de las ecuaciones de equilibrio

Sumatoria de momentos en nudos 2, 3, y 5 igual a cero, tenemos tres ecuaciones y cuatro incógnitas, necesito una ecuación de equilibrio adicional  $\rightarrow$  ecuación de piso (sumatoria de fuerzas verticales igual a cero)



Equilibrio de momentos en el nudo 2

$$\sum M_2 = 0$$

$$M_{21} + M_{23} + M_{25} = 0$$

Para hacer el equilibrio de nudos tomamos  
Acción de barra sobre nudo  
(positivo en sentido horario)

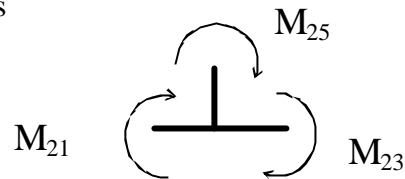

$$M_{21} \rightarrow -0.75 \quad +3.053 \omega_2 \quad +6.107 \psi_{23}$$

$$M_{23} \rightarrow +1.00 \quad +2.290 \omega_2 \quad +1.145 \omega_3 \quad -3.435 \psi_{23}$$

$$M_{25} \rightarrow \quad +1.333 \omega_2 \quad +0.667 \omega_5$$

	+0.25	+6.676 $\omega_2$	+1.145 $\omega_3$	+0.667 $\omega_5$	+2.672 $\psi_{23} = 0$ (I)
--	-------	-------------------	-------------------	-------------------	----------------------------

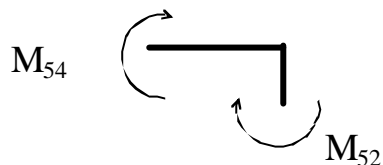
Equilibrio de momentos en el nudo 5

$$\sum M_5 = 0$$

$$M_{52} + M_{54} = 0$$

$$M_{54} \rightarrow + -0.75 \quad +1.333 \omega_5 \quad +2.667 \psi_{23}$$

$$M_{52} \rightarrow \quad +1.333 \omega_5 \quad +0.667 \omega_2$$

	-0.75	+2.667 $\omega_5$	+2.667 $\psi_{23}$	+0.667 $\omega_2 = 0$ (II)	
--	-------	-------------------	--------------------	----------------------------	--

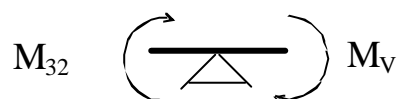
Equilibrio de momentos en el nudo 3

$$\sum M_3 = 0$$

$$M_{32} + M_v = 0$$

$$M_{32} \rightarrow + -1.00 \quad +1.145 \omega_2 \quad +2.29 \omega_3 \quad -3.435 \psi_{23}$$

$$M_v \rightarrow +1.00$$

	0.00	+1.145 $\omega_2$	+2.29 $\omega_3$	-3.435 $\psi_{23} = 0$ (III)	
--	------	-------------------	------------------	------------------------------	--

Ecuación de piso

$$\sum F_v = 0$$

$$+Q_{21} + Q_{54} - Q_{23} = 0$$

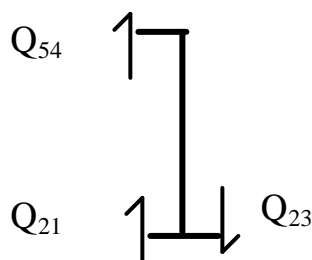

Nota. Para hallar los esfuerzos de corte debidos al momento flector en las distintas barras aplico momentos positivos (ya que todavía no conozco su valor) en los extremos de barras. (Acción de nudo sobre barra positivo en sentido antihorario)

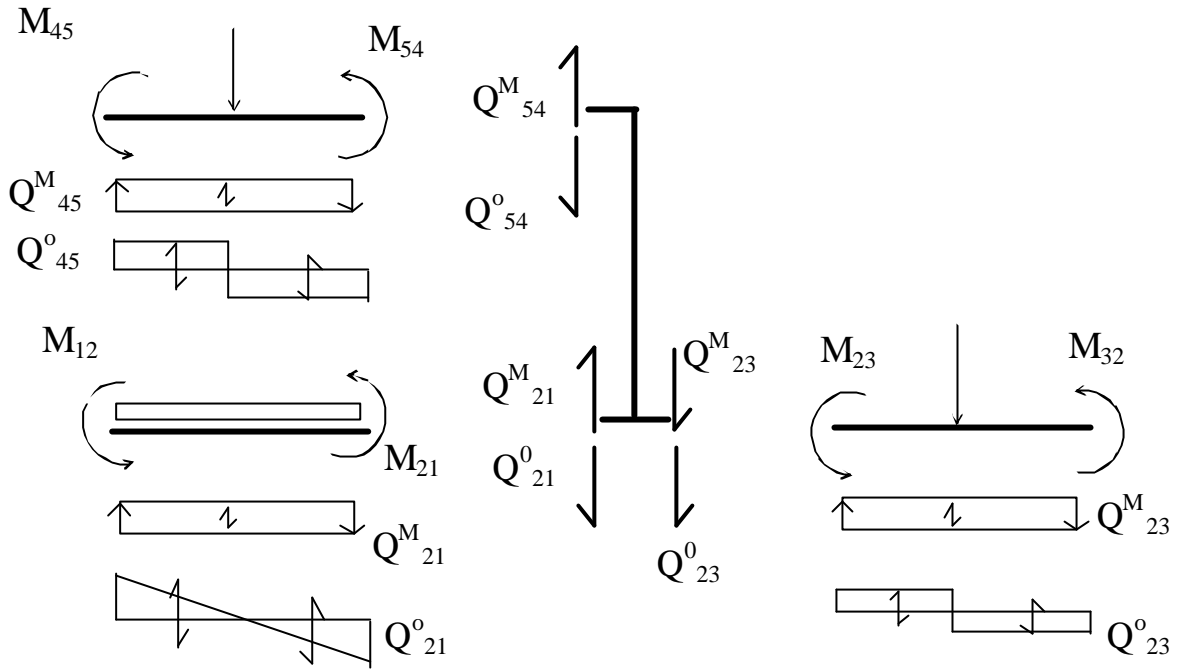

$$Q^M_{54} = (M_{54} + M_{45}) / L_{45} = 0.667 \omega_5 + 1.778 \psi_{23}$$

$$Q^M_{21} = (M_{21} + M_{12}) / L_{12} = 1.5267 \omega_2 + 4.071 \psi_{23}$$

$$Q^M_{23} = (M_{23} + M_{32}) / L_{23} = 0.8587 \omega_2 + 0.8587 \omega_3 - 1.7175 \psi_{23}$$

$$\sum F_V = 0$$

$Q^M_{54} \rightarrow$	$0.667 \omega_5$	$+1.778 \psi_{23}$	
$-Q^o_{54} \rightarrow$			$-1.00$
$Q^M_{21} \rightarrow$	$1.5267 \omega_2$	$+4.071 \psi_{23}$	
$-Q^o_{21} \rightarrow$			$-1.50$
$-Q^M_{23} \rightarrow$	$-0.8587 \omega_2$	$-0.858 \omega_3$	$+1.7175 \psi_{23}$
$-Q^o_{23} \rightarrow$			$-1.00$

$0.6679\omega_2$	$-0.858 \omega_3$	$0.667 \omega_5$	$+7.566 \psi_{23}$	$-3.50=0$	(IV)
------------------	-------------------	------------------	--------------------	-----------	------

Resolviendo el sistema de ecuaciones obtenemos:

$$\bar{\omega}_2 = -0.49536 \quad \bar{\omega}_3 = 1.25644 \quad \bar{\omega}_5 = -0.267409$$

$$\bar{\psi}_{23} = 0.67251$$

Reemplazando los valores de las rotaciones en las ecuaciones de recurrencia obtenemos los momentos flectores en las barras y a partir de los mismos los esfuerzos de corte, normal y diagrama del cuerpo libre.

$$\begin{array}{llll} M_{12} = 4.1 \text{ tm} & M_{23} = -1.006 \text{ tm} & M_{25} = -0.84 \text{ tm} & M_{45} = 2.365 \text{ tm} \\ M_{21} = 1.844 \text{ tm} & M_{32} = -1.00 \text{ tm} & M_{52} = -0.69 \text{ tm} & M_{54} = 0.687 \text{ tm} \end{array}$$

#### DIAGRAMA DE MOMENTOS

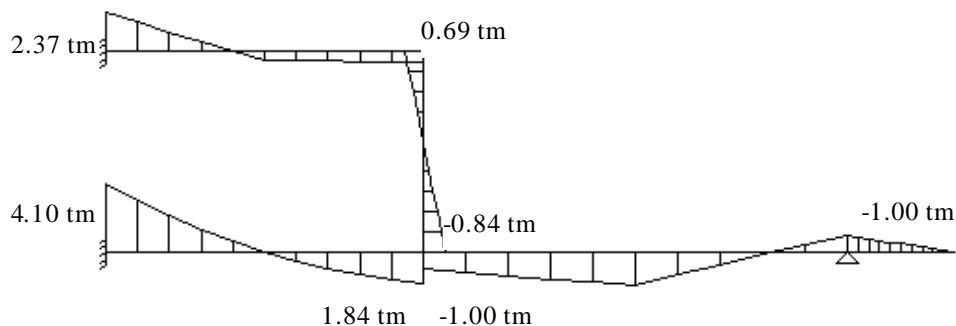

#### DIAGRAMA DE CORTE

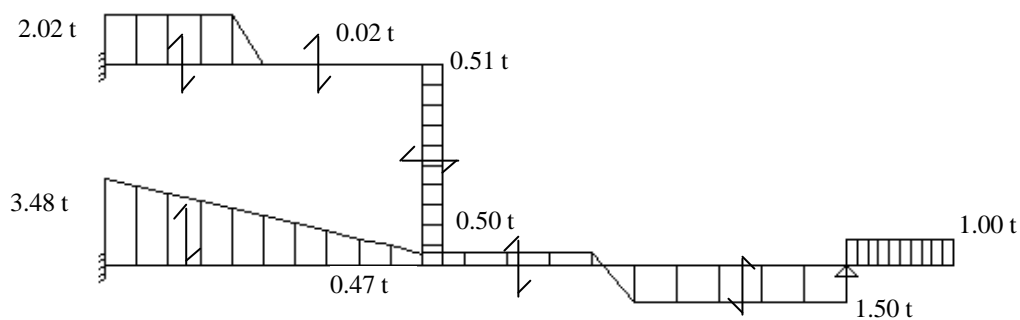

#### DIAGRAMA DE N

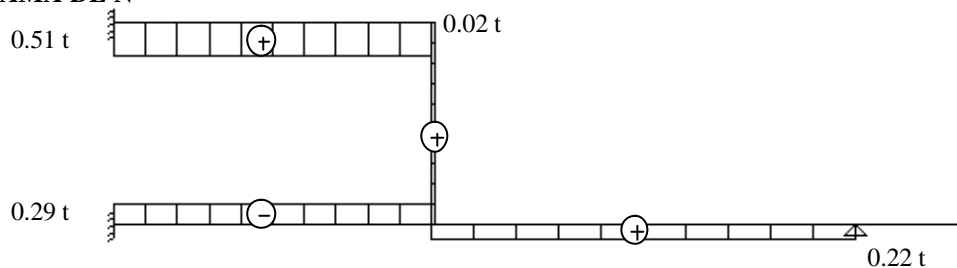

#### ESTRUCTURA DEFORMADA

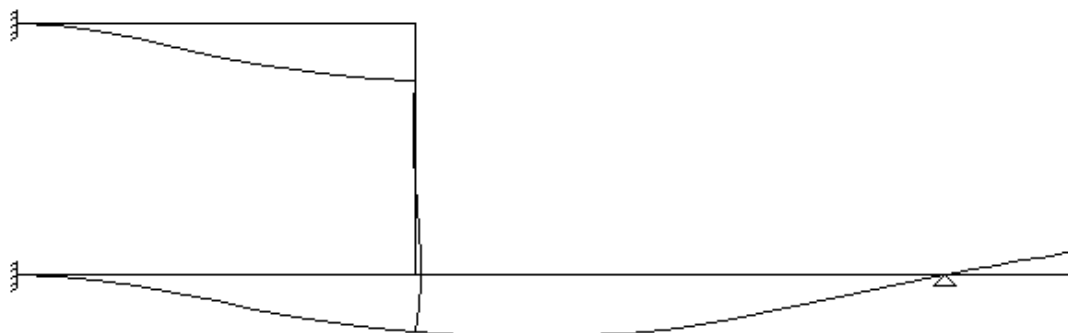

## DIAGRAMA DEL CUERPO LIBRE

